

DEPARTMENT OF THE ARMY TECHNICAL BULLETIN

INSTALLATION AND REMOVAL INSTRUCTIONS FOR THE TRIMBLE TRIMPACK GLOBAL POSITIONING SYSTEM (GPS) SPECIAL MISSION KITS ON OH-58C (ROUND GLASS) HELICOPTERS

Headquarters, Department of the Army, Washington, D.C.

15 June 1995

DISTRIBUTION STATEMENT A. Approved for public release; Distribution is unlimited.

NOTE

THIS PUBLICATION IS EFFECTIVE INDEFINITELY UNLESS SOONER RESCINDED OR SUPERSEDED.

1. **PRIORITY.** This technical bulletin is classified **ROUTINE**.

2. **PURPOSE.** This Technical Bulletin to only be applied if dictated by mission requirements. It provides Instructions for the temporary Installation of provisions for a GPS Trimpack receiver on the upper center surface of the main Instrument panel glareshield in the cockpit and a remote antenna on the upper wire strike cutter. When the GPS is installed, it will provide the copilot/observer with information on aircraft position for navigation.

3. **APPLICABLE END ITEM(S) OR SYSTEM(S).**

System(s) affected.

NOMENCLATURE	NSN	PART NO.	CAGE	TYPE/ MODEL	SERIAL NO. RANGE
Helicopter, Observation	1520-01-020-4261	OH-58C	97499	OH-58C	As dictated by mission requirements. See note below.

NOTE

Each Installation of the Trimble Trimpack GPS requires prior approval of units MACOM. Operation of GPS shall be in accordance with Interim Statement of Airworthiness Qualification (ISAQ) dated 6 March 1995 or later revision.

**4. KIT(S)/PART(S) AND THEIR DISPOSITION.****NOTE**

Before starting application do a complete inventory of both kits.

a. Kit(s)/part(s) needed for this application:

<b>Nomenclature</b>	<b>NSN</b>	<b>CAGE</b>	<b>Part Number</b>	<b>Security</b>	<b>Weight</b>
Kit A	5895-01-3405501	20309	90209246-501	Normal	7.0 lbs.
Kit B				Normal	
Antenna, GPS		65457	12038-00 or 16248-40		0.3 lbs.
Receiver, Trimble Trimpack ANVIS Modification Kit	5895-01-340-5502	65457 80063	16768-10 or 1676820 A3154590-2		4.2 lbs. 1.0 lb

b. Contents of Kit A:

<b>NOMENCLATURE</b>	<b>NSN</b>	<b>CAGE</b>	<b>PART NO.</b>	<b>QTY</b>
Cable, Power.	*	20309	90209183-504	1
Cable, Antenna	*	20309	90209182-506	1
Cable, Antenna	*	20309	90209182-507	1
Circuit Breaker, 1A	5925-00-929-7716	96906	MS26574-1	1
Clamp, Wire	5340-00-598-0146	96906	MS21919WDG-3	1
Mount, Antenna LS	*	20309	90209223-1	1
Mount, Antenna RS	*	20309	90209223-2	1
Template, Antenna	*	20309	90209223-3	1
Template, Connector	*	20309	90209223-4	1
Panel, Ant. Blankoff	*	20309	90209175-501	1
Placard	*	20309	90209223-5	1
Sleeve Assy, Trmpk	*	20309	90209178-501	1
Adapter, Support	*	20309	90209236-501	1
Adapter, Support	*	20309	90209236-502	1
Jumper Assy	*	20309	90209223-6	1
Terminal Lug #6	5940-00-204-8966	96906	MS25036-102	1
Terminal Lug #10	5940-00-143-4771	96906	MS25036-103	1
Strap, (Tywrap)	5975-00-984-6582	96906	MS3367-1-0	20
Spacer	5365-00-723-2756	00756	NAS43DD3-44	1
Bolt, Machine	5306-00-151-0785	88044	AN3-7A	3
Screw, .164-32	5305-00-984-6194	96906	MS35206-246	3
Screw, .190-32	5305-00-995-3440	96906	MS35207-270	1
Screw, .190-32	5305-00-989-6265	96906	MS35207-262	6
Screw, .164-32	5305-00-984-6196	88044	MS35206-248	4
Washer, Flat #8	5310-00-558-6207	88044	AN960C8L	8
Washer, Flat #10	5310-00-167-0812	88044	AN960C10L	18
Nut, Self Lock 10-32	5310-00-807-1474	96906	MS21042L3	9

\*NSN to be assigned

b. Contents of Kit B (Obtain as individual components):

NOMENCLATURE	NSN	CAGE	PART NO.	QTY
Antenna, GPS	5895-01-326-5583	65457	12038-00 or 16248-40 (Green)	1
Receiver, Trimble Trimpack		65457	1676810 or 1676820	1
ANVIS Modification Kit	5895-01-340-5502	80063	A3154590-2	1

**5. APPLICATION.**

a. Category of Maintenance: Aircraft downtime will be charged to AVUM Maintenance.

(1) AVIM for Kit A Installation.

(2) AVUM for Kit A removal and Kit B installation/removal.

b. Requirements: Work force and man-hour requirements for Kit A application of this technical bulletin(TB) to single unit, end item, or system Is as follows:

**REQUIREMENTS**

WORK FORCE/SKILLS	MAN-HOURS
Aircraft Electrician (1)	4
Sheet Metal Repairer (1)	1

Total man-hours required for single application of this TB is 5 hours.

c. TB/MWO(s) to be applied prior to or concurrently this TB. Not Applicable.

**6. PUBLICATIONS WHICH REQUIRE CHANGE AS A RESULT OF THIS TECHNICAL BULLETIN.** Not Applicable.

**NOTE**

Operator and Maintenance Guide will be provided with GPS Trimpack Receiver.

**7. SUPPLY/PARTS AND THEIR DISPOSITION.**

Bulk and expendable material.

NOMENCLATURE	NSN	CAGE	PART NO.	QTY
Chemical Conversion Coating (Alodine 600)	8030-01-018-2838	80244	MIL-C-81706, CI 3, FM 2	KT
Primer Coating Kit, Epoxy	8010-01-314-6076	81349	M23377-21-0012	KT
Sealant	8030-00-723-2746	81205	MIL-S-8802	KT
Tape, Pressure Sensitive	7510-00-283-0612	99742	PPP-T-42	YD
Coating, Aliphatic Polyurethane	8010-01-316-2221	81349	MIL-C-46168	KT

**8. SPECIAL TOOLS; TOOL KITS; JIGS; TEST, MEASUREMENT AND DIAGNOSTIC EQUIPMENT (TMDE); AND FIXTURES REQUIRED.**

NOMENCLATURE	NSN	CAGE	PART NO.	QTY
Multimeter	6625-00-9997465	80058	AN/USM-223 (or equivalent)	1

**9. INSTALLATION PROCEDURES FOR KIT A.** The following procedures contain Instructions for Installing/ removing the GPS Trimpack and provisions on OH-58C helicopters.

**CAUTION**

- To prevent damage or loss, items removed to gain access to work areas shall be tagged for Identification and protected from damage before reinstallation. Retain all attaching hardware and identification markers unless otherwise directed.
- Ensure that a foreign object damage (FOD) prevention program is Implemented during application of this TB in accordance with AR 385-95, Chapter 4.

**NOTE**

- Refer to TM 55-1520-228-23 and TM 11-1520-228-23 for detailed removal and installation Instructions not contained herein and TM 55-1520-228-23P for detailed parts location.
- Refer to TM 55-1500-323-24 for detailed instructions concerning aircraft electrical and electronic wiring Installation practices.
- Refer to TM 1-1500-204-23 for detailed instructions concerning aircraft sheet metal practices.
- Refer to TM 55-1500-345-23 for painting and marking practices.
- If Trimpack Sleeve Assembly (P/N 90209-501) has not been modified, modify per Figure 8.

a. Aircraft preparation.

(1) Prepare aircraft for safe ground maintenance.

(2) Lower overhead console circuit breaker panel for access to power distribution wiring.

(3) Remove upper cabin sound proofing blanket as required to gain access to wire bundles and GPS antenna cable routing.

b. Prepare upper wire strike cutter for installation of Trimpack remote antenna mounts P/N 90209223-1 and P/N 90209223-2) (Figure 1).

**NOTE**

If hole exists In upper wire strike cutter approximately 4.94 inches down from top aft corner of cutter go to step (1) below. If no hole exists go to step (2) below.

(1) Align center hole in template (P/N 90209223-3) with hole In cutter.

(a) Secure template (P/N 90209223-3) to cutter with bolt (P/N AN3-7A), washer (P/N AN960C10L) and nut (P/N MS21042-L3).

(b) Using template (P/N 90209223-3) as a guide, drill two pilot holes through cutter.

(c) Remove bolt (P/N AN3-7A), washer (P/N AN960C10L) and nut (P/N MS21042-L3) from template and cutter. Remove template.

(d) Ream out two holes in cutter to 0.204 inches.

(e) Clean and deburr holes.

(f) Go to step (3) below.

(2) Align template (P/N 90209223-3) with top edge of cutter.

(a) Using template (P/N 90209223-3) as a guide, drill three pilot holes through cutter.

(b) Remove template.

(c) Ream out three holes in cutter to 0.204 inches.

(d) Clean and deburr holes.

**WARNING**

Chemical conversion coating is flammable and toxic. It can irritate skin and cause burns. Use only in well-ventilated area, away from heat and open flame. Wear gloves, goggles, apron, and respirator. In case of contact, immediately flush skin or eyes with water for at least 15 minutes. Get medical attention for eyes.

**CAUTION**

Chemical conversion coating is highly corrosive. Do not allow chemical conversion coating or rinse water to run into cracks, crevices, seams, or joints.

(3) Surface treat antenna mount holes with Chemical Conversion Coating (MIL-C-81706).

**WARNING**

Epoxy primer coating and Aliphatic Polyurethane Coating are flammable and toxic. They can irritate skin and cause burns. Use only in well ventilated area away from heat and open flame. Wear approved respirator, apron solvent resistant rubber gloves and chemical splash goggles. Thoroughly wash skin area with soap and water. Flush eyes with water for 15 minutes. Get immediate medical attention for eyes.

(4) Prime antenna mount holes with epoxy primer coating (MIL-P-23377).

(5) Install antenna mounts (P/N 90209223-1 and P/N 90209223-2) on upper wire strike cover (Figure 1).

(a) Align mounts (P/N 90209223-1 and P/N 90209223-2) with previously drilled holes (Figure 1).

(b) Secure mounts to cutter with three bolts (P/N AN3-7A), six washers (P/N AN960C10L) and three nuts (P/N MS21042L3).

c. TrImpack Receiver Mount Installation Instructions (Figure 2).

(1) Remove three existing screws from upper surface of Instrument panel glareshield (Figure 2, view B). Retain screws.

(2) Position support adapter (P/N 90209236501) on glare shield.

(3) Secure support adapter to glareshield with three screws (P/N MS35206-246) and three washers (P/N AN960C8L) (Figure 2, view A-A).

(4) Install TrImpack sleeve assembly (P/N 90209178-501) on support adapter (P/N 90209236-501) (Figure 2, view A-A).

(5) Secure TrImpack sleeve assembly (P/N 90209178-501) to support adapter (P/N 90209236501) with two screws (P/N MS35207-262) and two washers (P/N AN960C10L) (Figure 2, view A-A).

d. Aircraft electrical and antenna wiring Instructions for TrImpack GPS.

(1) Remove existing damp from windshield center post (Figure 2, Section B-B).

(2) Position support adapter (P/N 90209236-502) on top of sleeve assembly (P/N 90209178-501) and align mounting holes.

(3) Transfer hole location from windshield center post to support adapter (P/N 90209236-502).

(4) Drill hole in support adapter (P/N 90209236-502).

(5) Clean and deburr hole,

**WARNING**

Chemical conversion coating is flammable and toxic. It can irritate skin and cause burns. Use only in well-ventilated area, away from heat and open flame. Wear gloves, goggles, apron, and respirator. In case of contact, immediately flush skin or eyes with water for at least 15 minutes. Get medical attention for eyes.

**CAUTION**

Chemical conversion coating is highly corrosive. Do not allow chemical conversion coating or rinse water to run into cracks, crevices, seams, or joints.

(6) Surface treat hole with Chemical Conversion Coating (MIL-C-81706).

<b>WARNING</b>
----------------

Epoxy primer coating and Aliphatic Polyurethane Coating are flammable and toxic. They can irritate skin and cause burns. Use only in well ventilated area away from heat and open flame. Wear approved respirator, apron solvent resistant rubber gloves and chemical splash goggles. Thoroughly wash skin area with soap and water. Flush eyes with water for 15 minutes. Get Immediate medical attention for eyes.

- (7) Prime hole with epoxy primer coating (MIL-P-23377).
- (8) Secure support adapter (P/N 90209236-502) to windshield center post with screw (P/N MS35207-270), spacer (P/N NAS43DD3-44), five washers (P/N AN960C10L) and nut (P/N MS21042-L3) (Figure 2, Section B-B).
- (9) Secure support adapter (P/N 90209236-502) to sleeve assembly (P/N 90209178-501) with four screws (P/N MS35207-262), four washers (P/N AN960C10L) and four nuts (P/N MS21042-L3) (Figure 2, View A-A).
- (10) Remove **PROX WARN** circuit breaker (if installed) in overhead console. Stow wires.
- (11) Install circuit breaker (P/N MS26574-1) in **PROX WARN** location In overhead console (Figure 3).
- (12) Install GPS placard (P/N 90209223-5) on overhead console.
- (13) Starting at Trimpack mount, route power cable (P/N 90209183-504) forward and up left side of windshield center post along existing wire bundles to GPS circuit breaker (Figure 4, View B).
- (14) Install terminal lug (P/N MS25036-102) on end of power cable (P/N 90209183-504).
- (15) Install power cable (P/N 90209183-504) to load side of GPS circuit breaker (Figure 3, View A).
- (16) Install jumper assembly (PIN 90209223-6) from line side of **RDR ALT** circuit breaker to line side of GPS circuit breaker (Figure 3, View A).
- (17) Starting at Trimpack mount route power cable ground wire forward along existing wire bundles behind main instrument panel to local ground (Figure 4, View B).
- (18) Install terminal lug (P/N MS25036-103) on power cable ground wire.
- (19) Connect ground wire to local ground.
- (20) On upper exterior surface of cabin, locate first two rivets inboard of left upper wire strike cutter support.
- (21) Position connector template (P/N 90209223-4) over the two rivets (Figure 5, View C).
- (22) Drill pilot hole to locate RF bulkhead connector hole. Remove template.
- (23) Ream pilot hole out to 0.500 Inches.
- (24) Clean and deburr hole.

**WARNING**

Chemical conversion coating is flammable and toxic. It can irritate skin and cause burns. Use only in well ventilated area, away from heat and open flame. Wear gloves, goggles, apron, and respirator. In case of contact, immediately flush skin or eyes with water for at least 15 minutes. Get medical attention for eyes.

**CAUTION**

Chemical conversion coating is highly corrosive. Do not allow chemical conversion coating or rinse water to run into cracks, crevices, seams, or joints.

(25) Surface treat hole with Chemical Conversion Coating (MIL-C-81706).

**WARNING**

Epoxy primer coating and Aliphatic Polyurethane Coating are flammable and toxic. They can irritate skin and cause burns. Use only in well ventilated area away from heat and open flame. Wear approved respirator, apron solvent resistant rubber gloves and chemical splash goggles. Thoroughly wash skin area with soap and water. Flush eyes with water for 15 minutes. Get immediate medical attention for eyes.

(26) Prime hole with epoxy primer coating (MIL-P-23377).

(27) From inside cabin, install bulkhead lower antenna cable connector (P/N 90209182-507) with sealant (MIL-S-8802) in 0.500 inch hole.

(28) Secure cable connector with lockwasher and nut.

(29) Continue routing antenna cable forward along existing wire bundles, down windshield center post to GPS Trimpack mount.

(30) Secure antenna cable to existing wire bundles with tywraps (P/N MS3367-1-0).

(31) On upper surface of cabin connect upper antenna cable (P/N 90209182-506) to bulkhead connector (Figure 5, View D).

(32) Route cable up wire strike cutter to antenna mount (Figure 5, View D).

(33) Connect upper antenna cable (PIN 90209182-506) to antenna blankoff panel connector (P/N 90209175-501) (Figure 5, View D).

(34) Install antenna blankoff panel (P/N 90209175-501) on GPS antenna mount (Figure 5, View D).

(35) Secure blankoff panel to antenna mount with four screws (P/N MS35206-248) and four washers (P/N AN960C8L) (Figure 5, View D).

(36) Secure antenna cable to wire strike cutter support with tywraps (P/N MS3367-1-0) (Figure 5, View D).

(37) Install clamp (P/N MS21919WDG3) to lower mounting bolt on antenna mount (Figure 5, View D).



(38) Secure antenna cable to antenna mount with clamp (P/N MS21919WDG3) (Figure 5, View D).

e. Final procedures.

(1) Perform continuity check on coax cable for Trimpack remote antenna.

(2) Close access to overhead console circuit breakers and wiring.

(3) Install overhead cabin sound proofing blanket.

(4) Connect aircraft battery.

(5) Apply aircraft power to provide 28 VDC to GPS circuit breaker.

(6) Verify pin B of GPS five pin audio connector is common with airframe ground.

(7) Verify that pin D has 28VDC (Figure 7).

#### 10. KIT B INSTALLATION PROCEDURES.

a. Remove GPS antenna Blankoff panel (if installed) from GPS antenna mount (Figure 5, view D).

b. Connect GPS upper antenna cable to connector on GPS antenna (P/N 12038-00 or 16248-40).

c. Install GPS antenna on mount (Figure 6).

d. Secure with four screws (P/N MS35206-248) and four washer (P/N AN960C8L) (Figure 6).

#### NOTE

Only Trimble Trimpack GPS receiver P/N's 1676810 and 16768-20 are allowed for this installation. These receivers have software that compensates for the effects of rotor modulation and have green lighting. All other Trimble Trimpack receivers cannot be used. The P/N is located on a nameplate located between the receiver and battery pack. The battery pack must be moved to see the name plate. An ANVIS (Aviator's Night Vision Imaging System) filter modification kit (NSN 5895-01-340-5502) has been developed and when used with either GPS receiver will provide an ANVIS acceptable display. Installation instructions for this ANVIS filter modification are contained in document, ILS 91-ANV0002, dated March 1991 provided with the ANVIS kit.

e. Remove caps from GPS Trimpack receiver power connector and external antenna cable connector. Tape caps to side of receiver with tape (PPP-T-42) to prevent chafing

f. Install GPS Trimpack receiver in mount and secure with clamp assemblies (Figure 6).

g. Connect power and antenna cables to receiver (Figure 6).

#### 11. GPS CHECKOUT PROCEDURES.

a. Move aircraft to ramp area with good satellite visibility.

b. Apply aircraft power.

c. Apply power to Trimpack. Check that it acquires satellites visible at time of test. If GPS powers up and acquires satellites check is complete.

**NOTE**

If Trimpack receiver is removed from aircraft and operated on internal batteries external power connector cap must be installed.

d. If GPS does not power up and aircraft power is present:

- (1) Check GPS circuit breaker in.
- (2) Check power connections to Trimpack receiver.
- (3) Check power cable routing and connection to circuit breaker.

e. If GPS does not acquire satellites:

- (1) Check antenna cable connection to Trimpack receiver.
- (2) Check antenna cable connection to bulkhead connector.
- (3) Check antenna cable connection to GPS antenna.
- (4) Recheck antenna installation.

f. Aircraft power off.

**12. KIT B REMOVAL PROCEDURE.**

- a. Remove GPS antenna from mount.
- b. Disconnect GPS antenna cable.
- c. Connect GPS antenna cable to Blankoff panel (P/N 90209175-501).
- d. Install antenna Blankoff panel (PIN 90209175-501) on GPS antenna mount with four screws (PIN MS35206-248) and washers (P/N AN960C8L) (Figure 5).
- e. Remove Trimpack receiver from mount.
- f. Disconnect antenna and power cables.
- g. Install caps on Trimpack connectors.

**13. KIT A REMOVAL PROCEDURE.**

- a. Prepare aircraft for safe ground maintenance (TM 55-1520-228-23)
- b. Lower overhead console circuit breaker panel for access to power distribution wiring.
- c. Remove upper cabin sound proofing blanket as required to gain access to wire bundles and GPS antenna cable routing.

- d. Remove antenna blankoff panel from GPS antenna mount.
- e. Disconnect GPS antenna from antenna blankoff connector.
- f. Remove Trimpack remote antenna mounts (P/N 90209223-1 and P/N 90209223-2) from upper wire strike cutter.
- g. Remove GPS Trimpack support adapter (P/N 90209236-501) (figure 2).
- h. Remove GPS Trimpack sleeve assembly (PIN 90209178501) (figure 2).
- i. Remove GPS Trimpack support adapter (P/N 90209236-502) (figure 2).
- j. Install three screws In center upper surface of glareshield.
- k. Install clamp In windshield center post with shorter screw (Figure 2, Section B-B)
- l. Remove jumper wire from line side of **RDR ALT** circuit breaker and line side of **GPS** circuit breaker (Figure 3, View A).
- m. Remove GPS power wire from GPS circuit breaker.
- n. Remove circuit breaker (P/N MS26574-1) from overhead console (Figure 3).
- o. Remove GPS circuit breaker placard from overhead console (Figure 3).
- p. Disconnect GPS power cable ground terminal from ground behind main Instrument panel.
- q. Remove GPS power cable.
- r. Remove upper antenna cable (P/N 90209182-506) from bulkhead connector (P/N 90209182-507) on exterior surface of cabin.
- s. Remove bulkhead connector end of lower antenna cable (P/N 90209182-507) from upper cabin structure.
- t. Remove upper antenna cable.
- u. Remove lower antenna cable.
- v. Patch/repair antenna cable hole in upper cabin structure (TM 1-1500-204-23).
- w. Close access to overhead console circuit breakers and wiring.
- x. Install overhead cabin sound proofing blanket.

**14. WEIGHT AND BALANCE DATA.** Make entries on DD Form 365-1 (Chart A) and DD Form 365-3 (Chart C) In accordance with TM 55-1520-228-23 and TM55-1500-342-23, as Indicated below:

a. Chart A. Make the following entry (OH-58C Round Glass):

ITEM NO.	DESCRIPTION	WEIGHT (lbs.)	ARM (In.)	Moment/100 (in lbs)
A-	GPS Antenna	0.3	35.0	0.20
A-	GPS Receiver, Trimpack	4.2	37.0	1.60

b. Chart C. Make the following entry (OH-58C Round Glass):

ITEM NO.		DESCRIPTION	ADDED (+)			REMOVED (-)		
IN	OUT		WT.	ARM	MOM/100	WT.	ARM	MOM-100
A-		TB 1-1520-228-20-79 Provision for GPS Receiver	2.8	38.3	1.07			

**15. RECORDING AND REPORTING REQUIREMENTS.**

Records and Reports.

The following forms are applicable and are to be completed in accordance with DA PAM 738-751, TAMMS-A.

- (1) DA Form 2408-5, Aircraft Equipment Modification Record.
- (2) DA Form 2408-13, Aircraft Status Information Record.
- (3) DA Form 2408-13-1, Aircraft Inspection and Maintenance Record.
- (4) DA Form 2408-13-2, Related Maintenance Action Record.
- (5) DA Form 2408-13-3, Technical Inspector Worksheet.
- (6) DA Form 2408-15, Historical Record for Aircraft.

**16. Points of Contact for this Technical Bulletin.**

(a) Technical is Mr. Peter Nyquist, DSN 995-3542 or commercial (908) 5443542 or Mr. Jeff Dworkin, DSN 624-2119 or Commercial (908) 323-2119.

(b) Logistical is Ms. Evelyn Thomas DSN 693-5568 or Commercial (314) 263-5568.

(c) Forms and Records Is Mrs. Ann Waldeck, AMSAT-I-MDM, DSN 693-1821 or commercial (314) 263-1821.

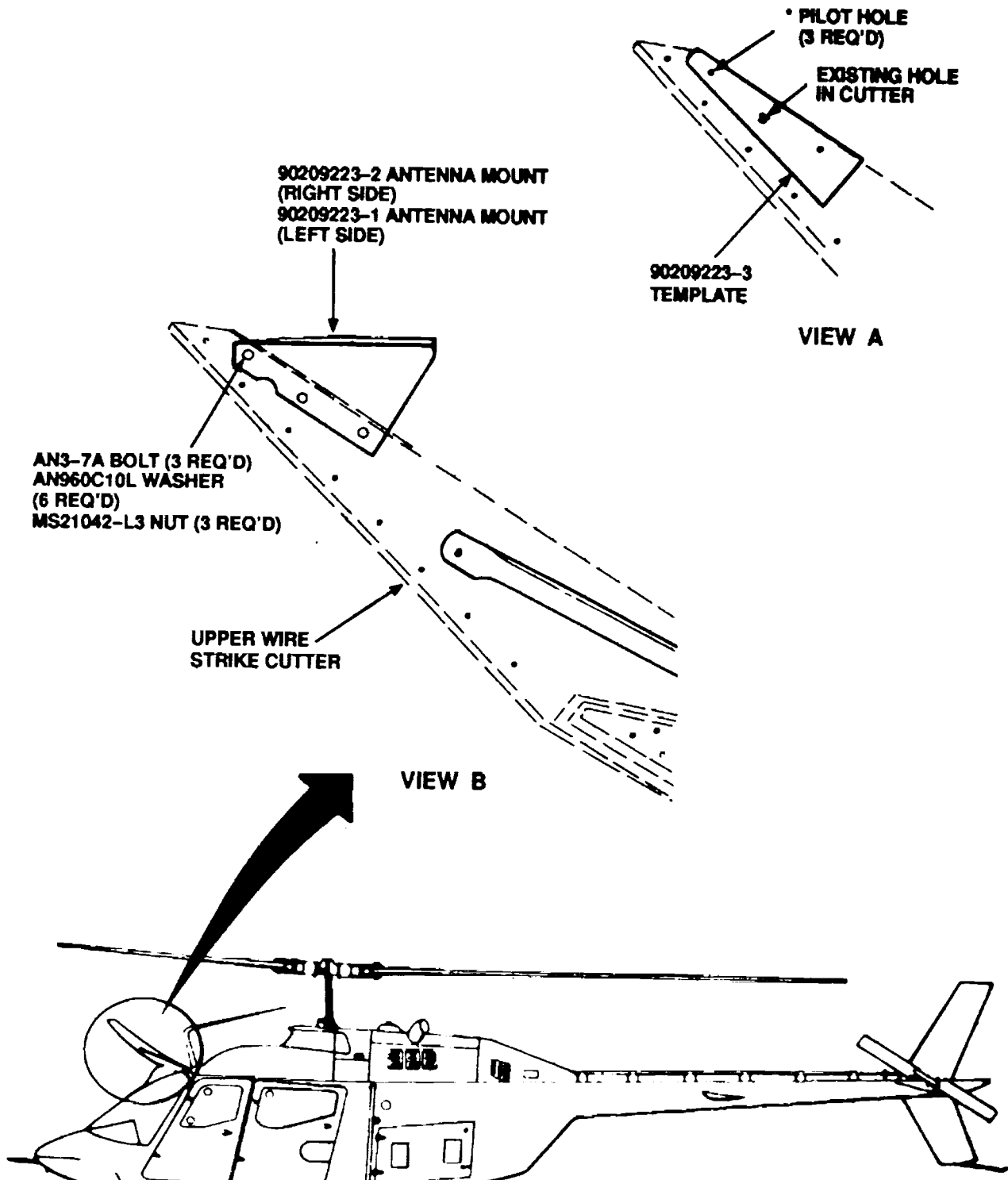

Figure 1. GPS Antenna Mount Installation.

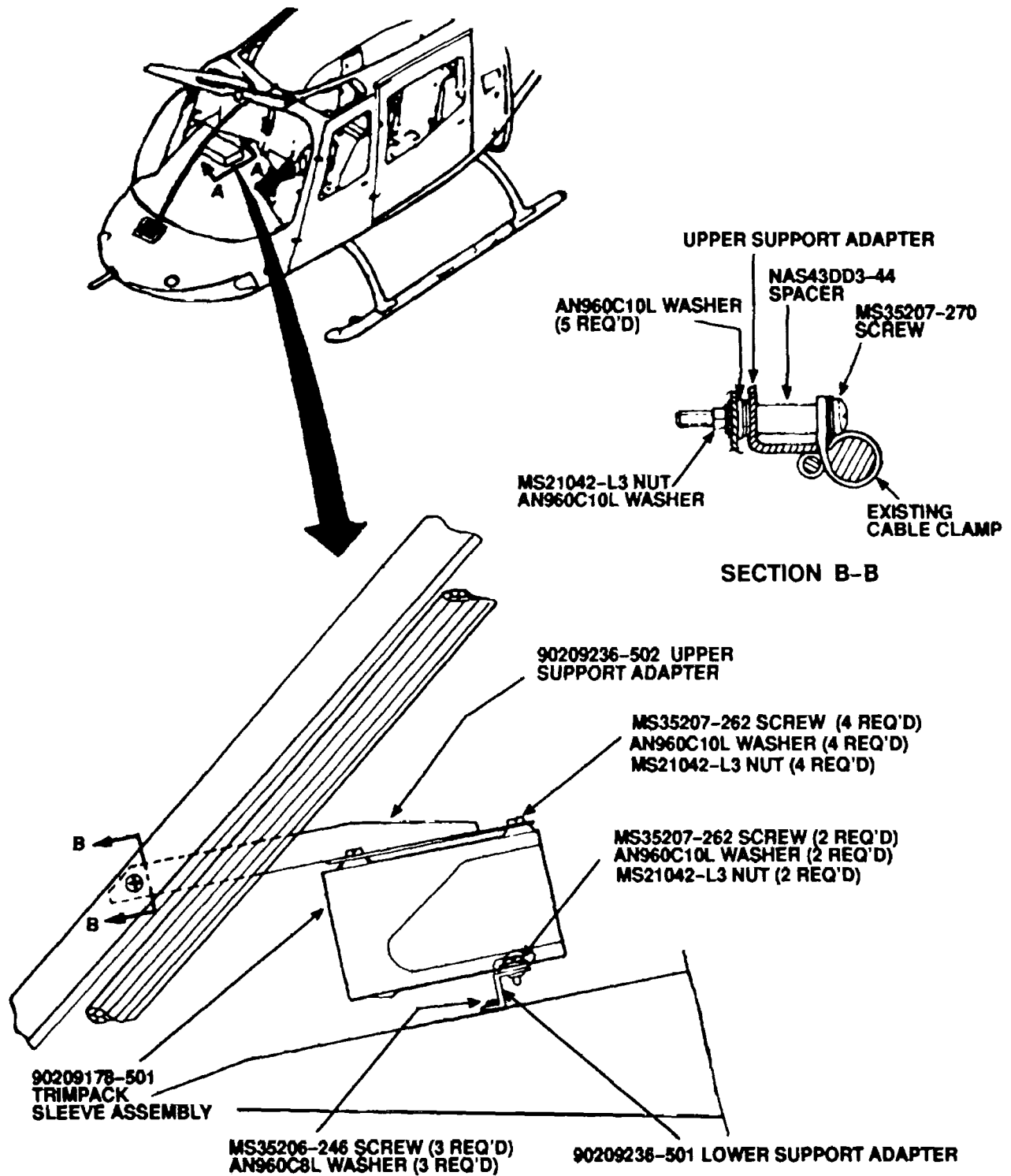

Figure 2. GPS Trimble Trimpack Receiver Mount Installation.

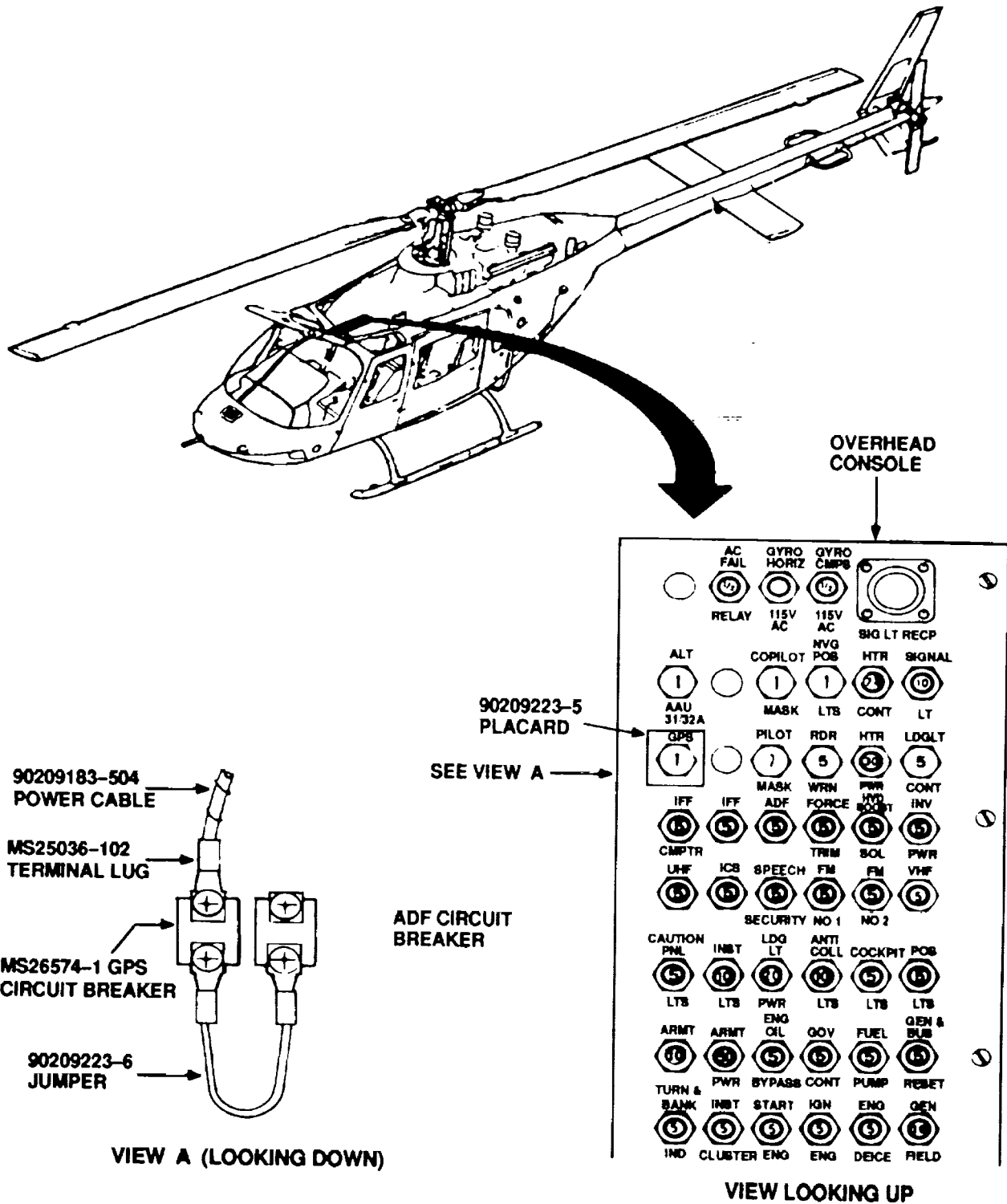

Figure 3. GPS Power Cable and Upper Console Installation.



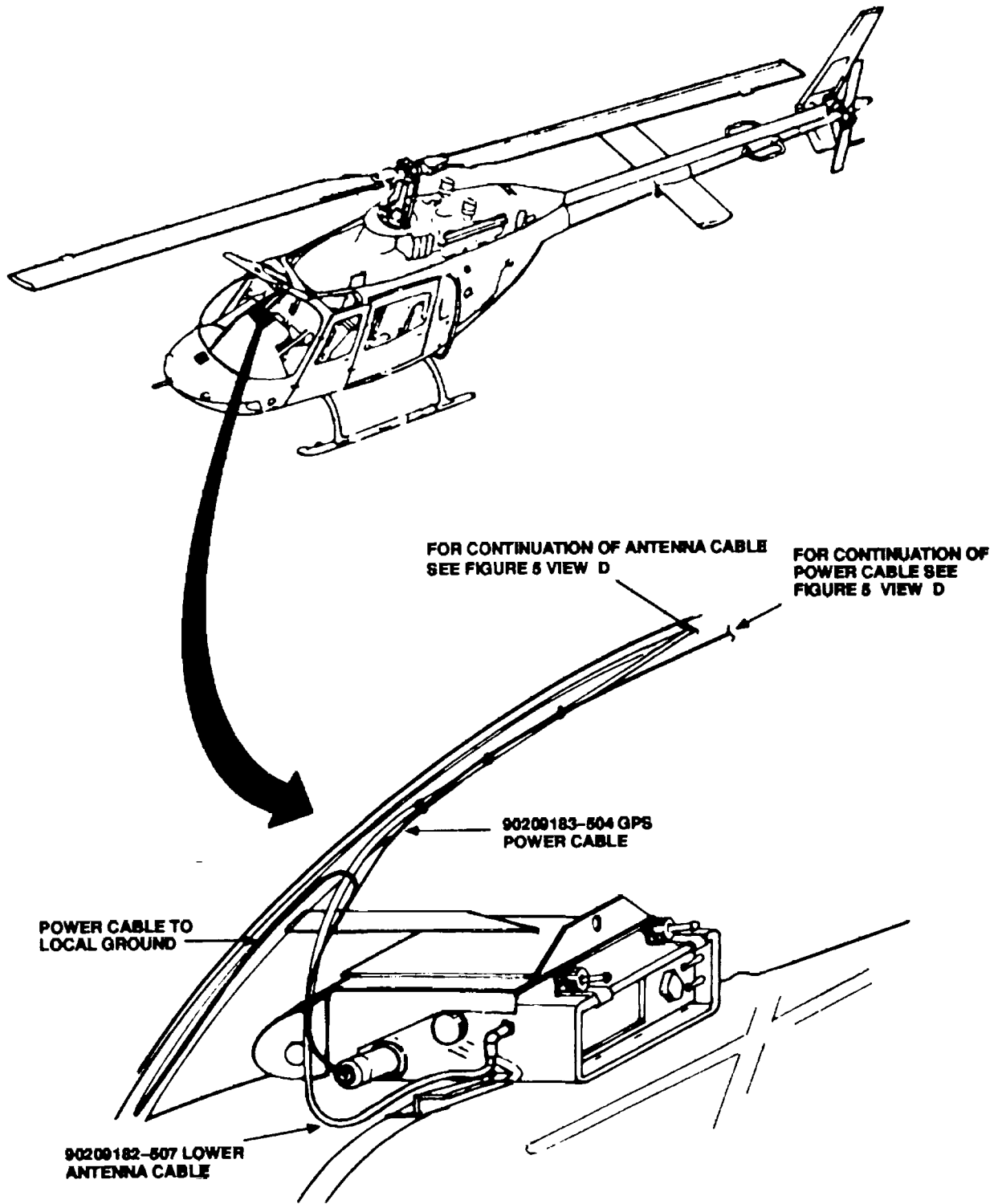

Figure 4. GPS Power Cable and Antenna Cable Installation.

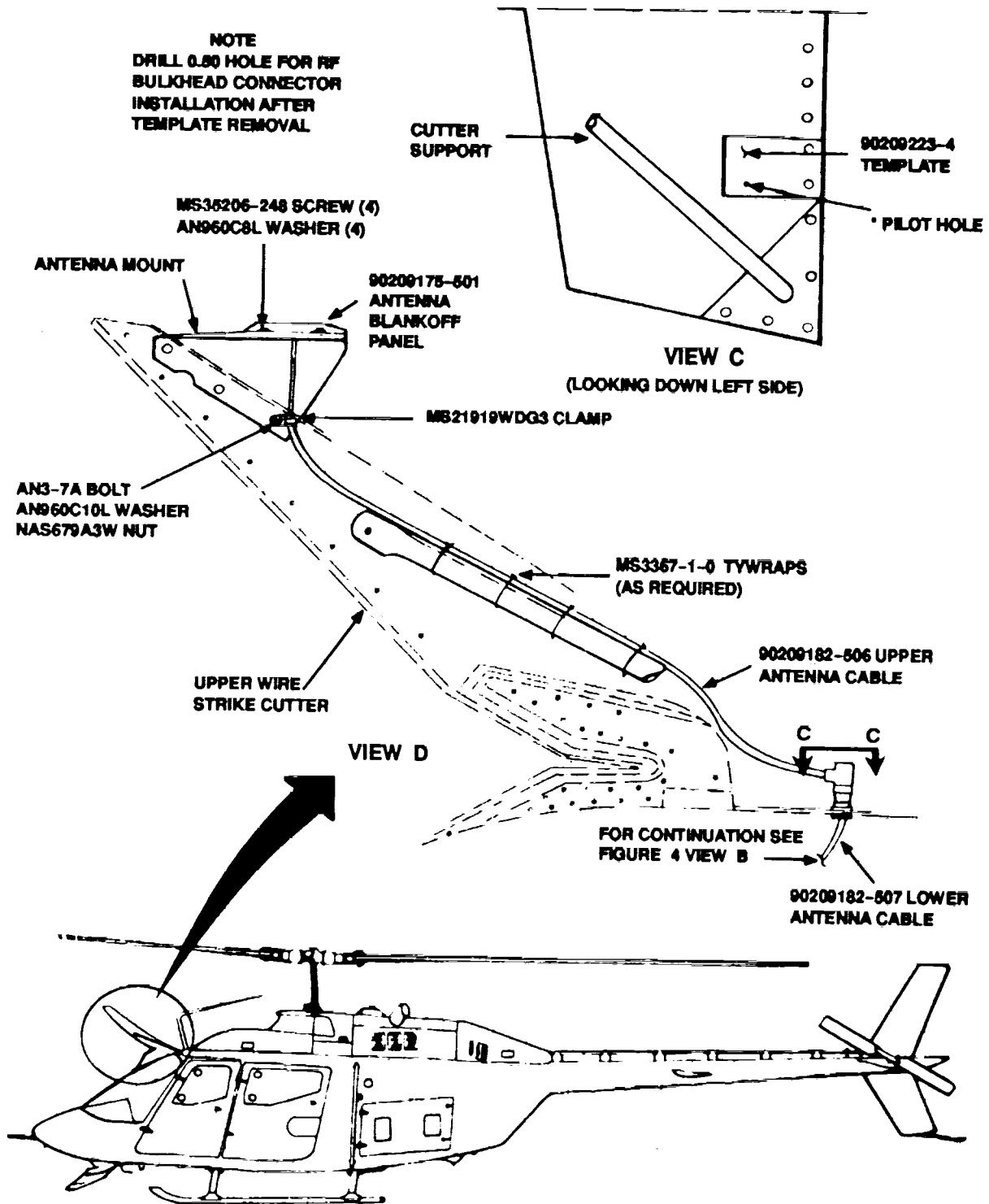

Figure 5. GPS Power Cable and Antenna Installation.

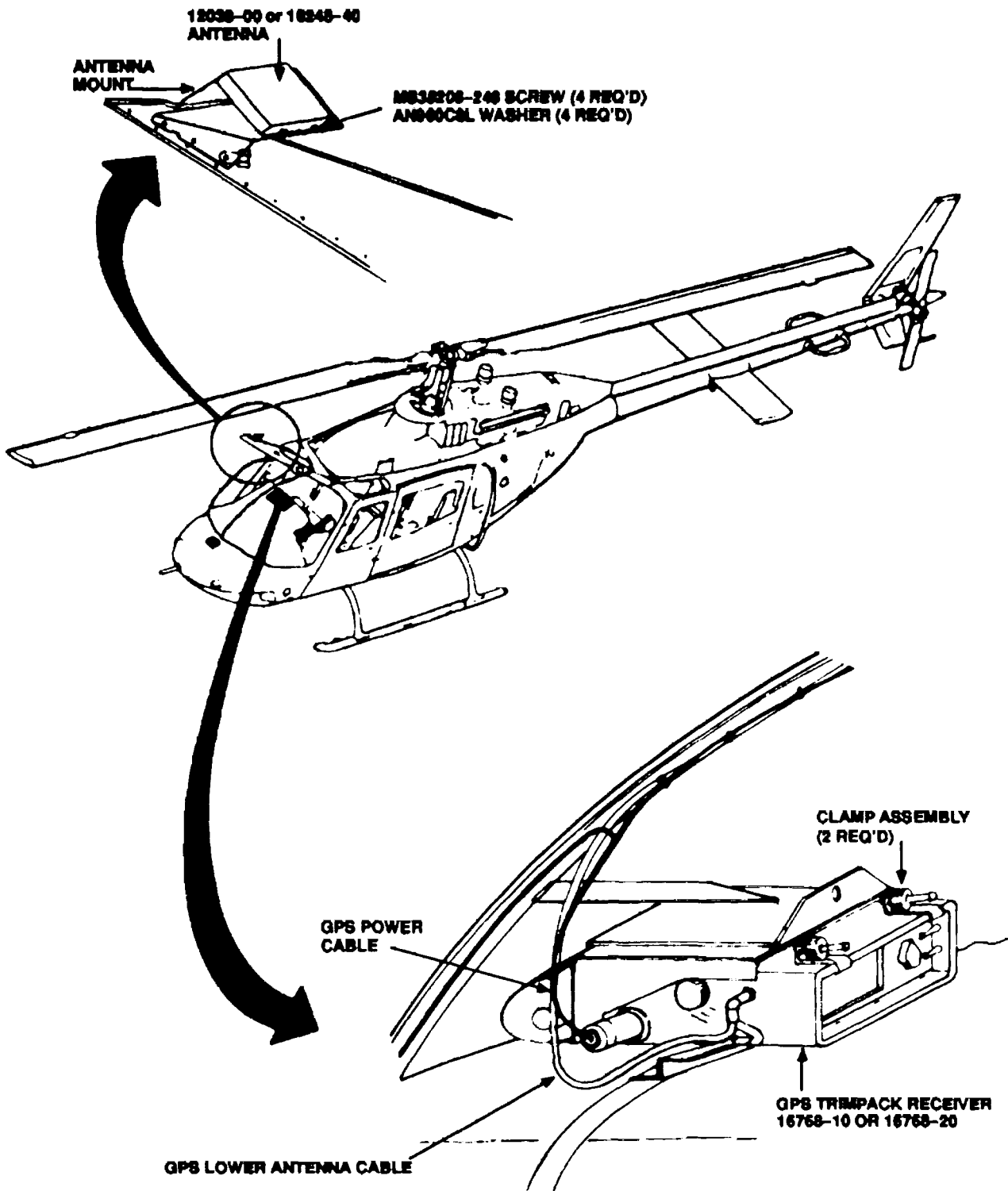

Figure 6. GPS Antenna and Trimpack Receiver Installation.

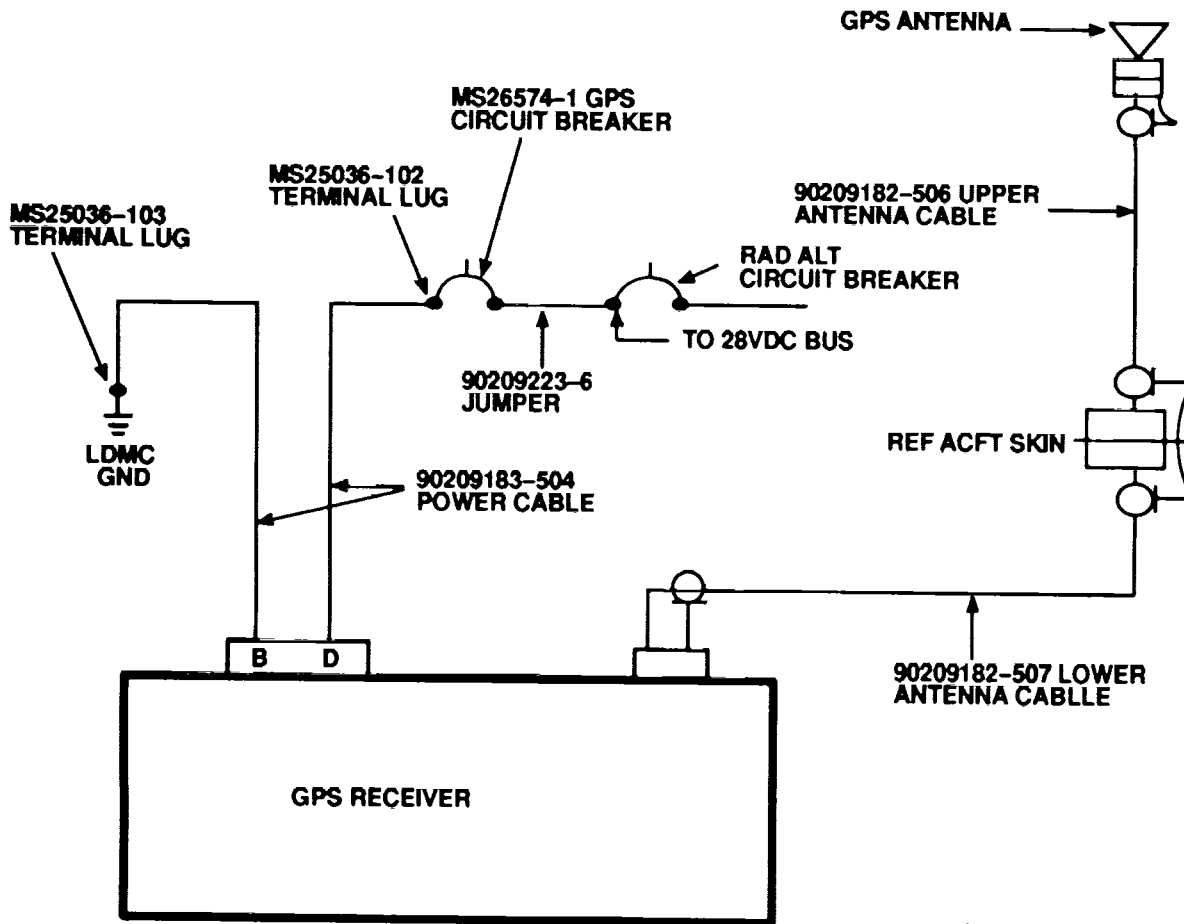

Figure 7. GPS Wiring Diagram.

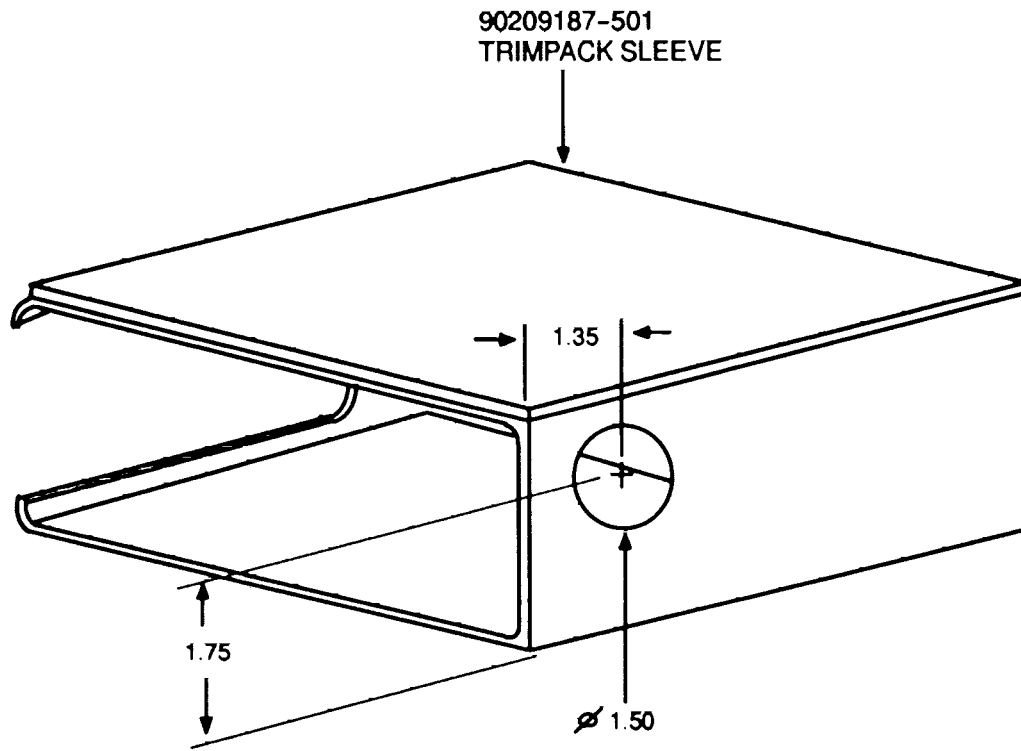

Figure 8. Trimpack Sleeve Modification.

**TB 1-1520-228-20-79**

**By Order of the Secretary of the Army:**

GORDON R. SULLIVAN  
*General, United States Army*  
*Chief of Staff*

Official:



Joel B. Hudson

*Acting Administrative Assistant to the*  
*Secretary of the Army*

00466

**DISTRIBUTION:**

To be distributed in accordance with DA Form 12-31-E, block no. 3489, requirements for  
TB 1-1520-228-20-79.

RECOMMENDED CHANGES TO EQUIPMENT TECHNICAL PUBLICATIONS



*THEN...JOT DOWN THE  
DOPE ABOUT IT ON THIS FORM.  
CAREFULLY TEAR IT OUT, FOLD IT  
AND DROP IT IN THE MAIL.*

**SOMETHING WRONG WITH PUBLICATION**

FROM: (PRINT YOUR UNIT'S COMPLETE ADDRESS)

DATE SENT

PUBLICATION NUMBER

PUBLICATION DATE

PUBLICATION TITLE

BE EXACT PIN-POINT WHERE IT IS

PAGE  
NO.

PARA-  
GRAPH

FIGURE  
NO.

TABLE  
NO.

IN THIS SPACE, TELL WHAT IS WRONG  
AND WHAT SHOULD BE DONE ABOUT IT.

PRINTED NAME, GRADE OR TITLE AND TELEPHONE NUMBER

SIGN HERE

